











En

ASSEMBLY INSTRUCTIONS
MODEL: CFT-POD

Part list:

A		Bolt M6X16	SC003	6PCS	B		Cover 1	PE003	9PCS
C		Bolt M8X16	SC072	2PCS	D		Cover 2	PE004	2PCS
E			HP849	1PC	F		Bolt M8X35	SC091	1PC
G			HPP0010	1PC	H		Bolt M6X13	SC004	3PCS
I			HP850	1PC	J		M6 WRENCH	RM002	1PC
K		M8 WRENCH	RM003	1PC					

Note:

Please un-screw bolts from legs and re-use them for assembly

Step1:

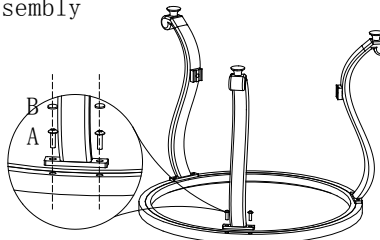

Step 2: MOUNT CENTER SUPPORT RING AS SHOWN

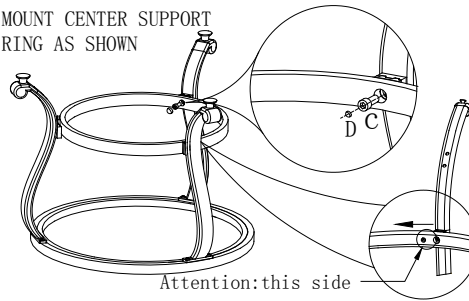

ASSEMBLY INSTRUCTIONS
MODEL : CFT-POD

Step 3: MOUNT IGNITION ASSEMBLY,
STEPS 3A,3B,3C AND 3D

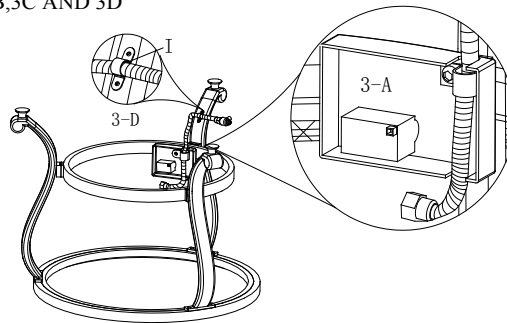

3-A: (FRONT VIEW)

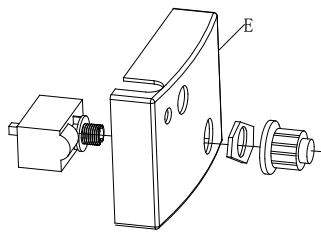

MOUNT IGNITOR SWITCH
TO SWITCH BOX

3-B:

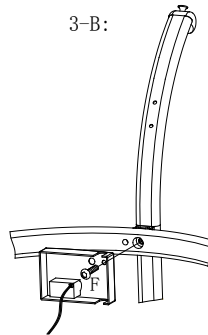

ASSEMBLY INSTRUCTIONS
MODEL : CFT-POD

3-C: (REAR VIEW)

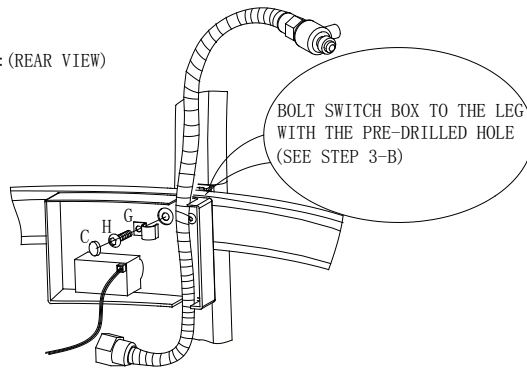

3-D: SCREW GAS LINE RETAINER CLIP INTO PRE-DRILLED HOLE IN LEG AS SHOWN

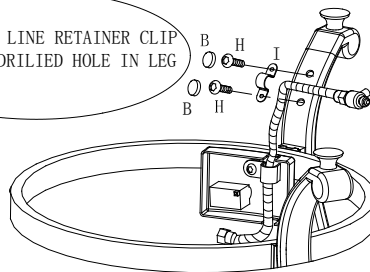

ASSEMBLY INSTRUCTIONS
MODEL : CFT-POD

Step4:

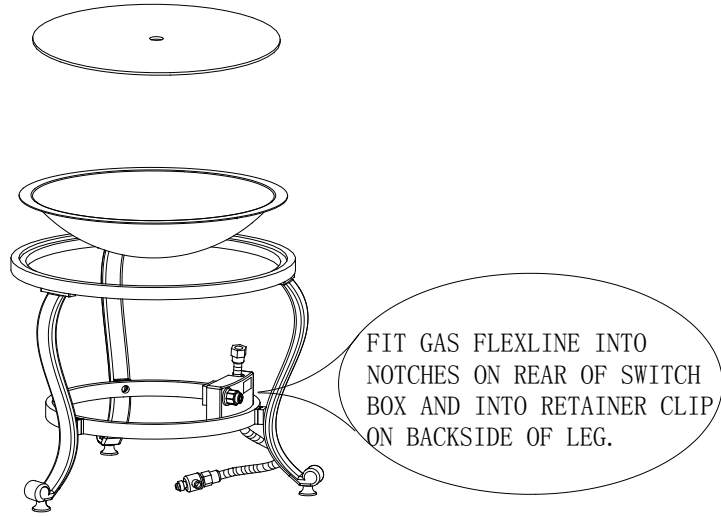

Completed Assembly:

