



10' x 12'

TITAN 
PERGOLA

I N S T R U C T I O N M A N U A L









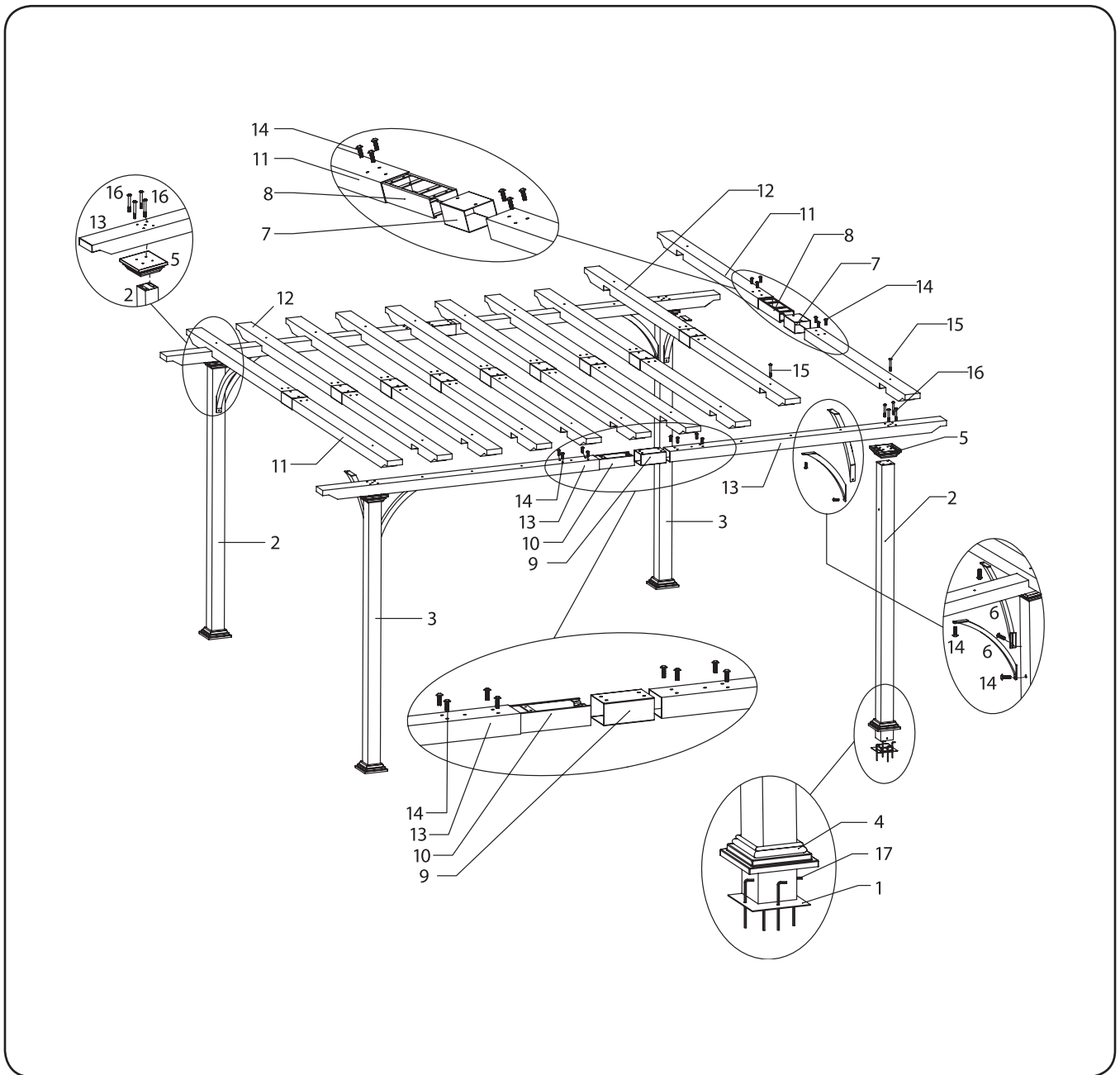











CARAVAN[®]
instant
canopies

14600 Alondra Blvd.
La Mirada, CA 90638
877-9-CANOPY
714-367-3000
Fax 714-367-3050
www.caravancanopy.com

ASSEMBLY DIAGRAM & PARTS LIST



Part	Name	Image	Qty
1	Lower Post Cap		4
2	Frame Post - L		2
3	Frame Post - R		2
4	Lower Base Cover		4
5	Upper Post Cap		4
6	Corner Bracket		8
7	Middle Beam Connector		10
8	Inner Middle Beam Connector		10
9	Long Beam Vertical Connector		2

Part	Name	Image	Qty
10	Inner Long Beam Connector		2
11	Middle Beam - A		4
12	Middle Beam - B		16
13	Long Beam		4
14	Small Screws		100
15	Medium Screws		20
16	Large Screws		16
17	Ground Stake		16
18	Allen Wrench		1

TITAN PERGOLA SET UP INSTRUCTIONS

Important:

- Do not remove numbered stickers until set up is complete.
- Requires a minimum of 3-4 people to assist with assembly

Tools Needed To Assemble:

- Cordless Drill/Screwdriver
- Ladders (2)

SET-UP ASSEMBLY

Step #1

Place lower base cover – part # 4 – onto bottom of frame posts – parts # 2 & # 3 (pic #1). Repeat this process on all four frame posts.



Step #2

Attach lower post cap – part # 1 – into frame post (pic #2) and secure with ground stakes - part # 17. Repeat this process on all four frame posts.

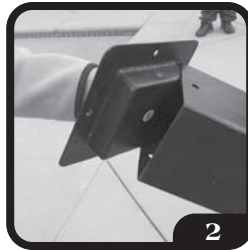

Step #3

Slide lower base cover now on frame post and over the lower post cap (pic #3).



Step #4

Attach upper post cap – part # 5 onto frame posts – parts # 2 & # 3 (pic #4A) making sure to line-up the screw hole openings with the post screw hole openings (pic #4B).



Step #5

Take the long beams - part # 13 and lay them down into 2 sets. Take the inner connector - part # 10 and insert (pic #5A) into 2 long beams to form one long beam. Then take the long beam connector - part # 9 and slide into center of newly formed long beam. Secure all of the above mentioned (pic #5B) with small screws - part # 14. Repeat this process for the other long beam.



Step #6

Take the middle beam A & middle beam B - parts #11 & 12 (pic #6A). Use the middle beam inner connector - part # 8 and middle beam connector - part # 7 (pic #6B) and repeat procedure for step 5. Once you have all 10 beams assembled, you are ready to attach to frame posts.



CONTINUED ON NEXT PAGE...>

SET-UP ASSEMBLY

Step #7

Connect 1 long beam (pic #7A) (2 total) to 2 of the frame posts with large screws. Repeat this step with remaining frame posts and long beam (pic # 7B).

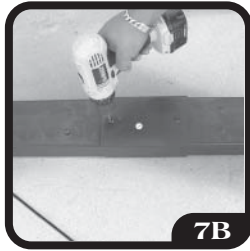

Step #8

Stand the assembled product from step #7 upright (pic. #8A). (Note: you will need a minimum of 3 people). Take the assembled middle beams from step #6 and place across the assembled structure from step #7 at a 90° angle, to form 3 sides of a rectangle (pic # 8B). Secure with medium screws - part # 15. Repeat this step for the remaining 9 middle beams (pics # 8C & 8D).

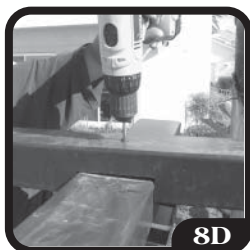

Step #9

Attach corner brackets - part #6 to frame post and connector beam (pic #9). Secure with small screws and repeat for all sides.



Step #10

Attach remaining beams onto frame posts (pic #10A). Secure all beams with medium screws (pic # 10B).



Step #11

Your Titan Pergola is now assembled for your enjoyment (pic # 11).



CARAVAN® 1-YEAR LIMITED WARRANTY

Caravan® Canopy Int'l warrants that each part of this product and the product itself will be free from defects in material and workmanship for twelve (12) months from date of purchase. This warranty is void if: [A] Product is used under other than normal use and maintenance conditions. [B] Product is modified or altered. [C] Product is subject to abuse or neglect. [D] Product damage is accidental or deliberate or caused by rain, wind or other forces of nature. [E] Product use does not conform to product instructions. [F] Product is repaired by someone other than Caravan® Canopy Int'l or its authorized representative.

The manufacturer's obligation is limited to replacing or repairing such defects during the warranty period at no charge.

If service is required, do not return the product to the store. Please contact Caravan® Canopy Int'l for specific shipping instructions before returning any part. All shipping costs must be pre-paid. A purchase receipt or other proof of purchase is required before warranty service is rendered. Caravan® Canopy Int'l will not be responsible for any products damaged in transit.

For a warranty claim call 877-9-CANOPY. Most service problems are resolved by replacing a broken or defective part. If this is not the case, we will give you instructions for returning the product. Return products to: Caravan® Canopy International Inc., 14600 Alondra Blvd., La Mirada, CA 90638 USA

After inspection, warranted products will be returned at no cost. If it is determined that products are not a warranty issue, it is the customer's responsibility to pay for repair and/or replacement parts and return shipping costs. If a problem with your canopy develops after the warranty period, please contact Caravan® Canopy Int'l for service. 877-9-CANOPY.

Under no circumstances will the retail customer, user, authorized representative or other person be entitled to any direct, special, indirect, consequential or exemplary damages for breach of contract or otherwise. Under no circumstances will any person be entitled to a sum greater than purchase price of the malfunctioning part.

No Caravan® Canopy Int'l authorized representative or person other than an officer of Caravan® Canopy Int'l may extend or modify this warranty. There are no other warranties from either Caravan® Canopy Int'l or its representatives which extend the face of this warranty. All other warranties, expressed or implied, including the warranties of merchantability, fitness for a particular purpose and fitness for use are excluded. See www.caravancanopy.com for further details.



14600 Alondra Blvd., La Mirada, CA 90638 USA
877-9-CANOPY • 716-367-3000 • Fax 714-367-3050
www.caravancanopy.com

rev.032009