

# ASSEMBLY INSTRUCTIONS

Eden™

Enduring Garden Architecture

www.edenarbors.com

## The Florence Arbor

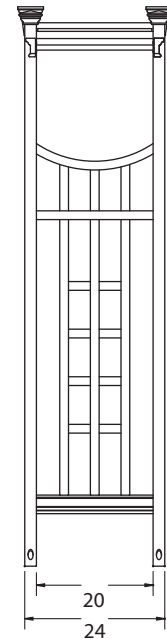
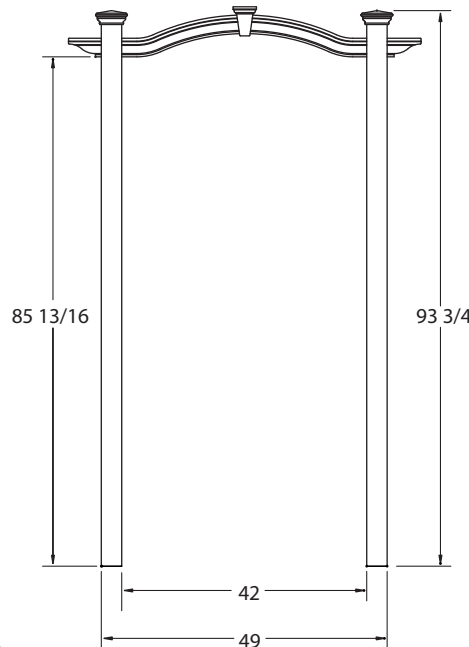
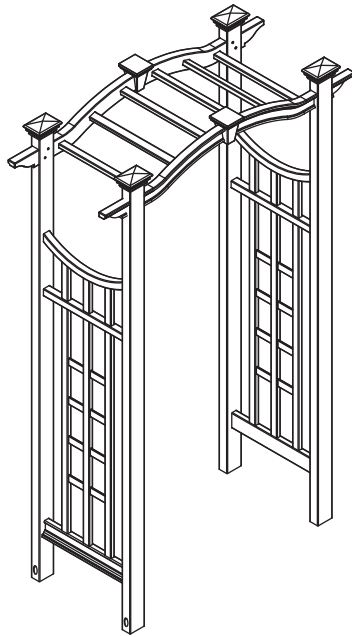

Please read through before starting assembly.

**IMPORTANT: CHECK THE INSIDE OF YOUR POSTS FOR ALL MATERIALS.**

### Check Box for These Contents

In the event of missing or defective parts please call our customer service dept. at **1 800 282 9346, ext #20** (Mon. to Fri. 8:00 AM to 4:00 PM EST).

1. Posts (4)
2. Post Caps (4)
3. Arches (4)
4. Arch Keystones & Lids (2)
5. Keystone Bottom Plates (2)
6. Arch Rafters (6)
7. Side Panel Horizontal Bent Top Rails (2)
8. Side Panel Horizontal Mid-Rails (2)
9. Side Panel Horizontal Spindles Short (8)
10. Side Panel Vertical Spindles Long (4)
11. Side Panel Vertical Spindles Short (2)
12. Side Panel Horizontal Bottom Rails (2)
13. Ground Anchoring Stakes (4)
14. Hardware (in plastic bag)
  - a) 1 1/2 Self-Auguring Stainless Steel Screws (16)
  - b) #2 Robertson Drill Bit (1)

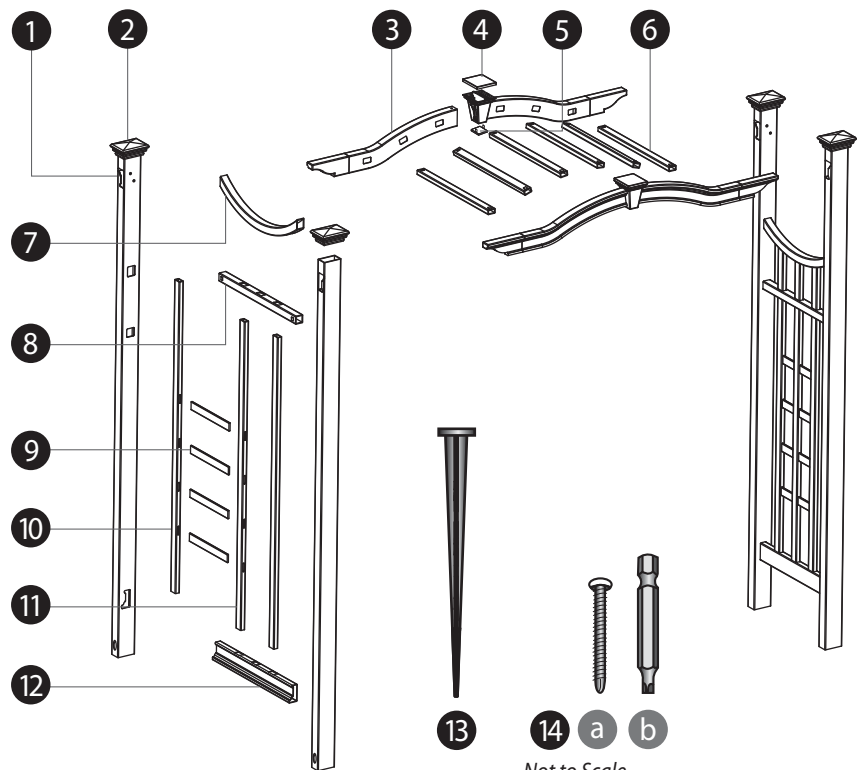

Not to Scale

### Tools You Will Need

- Cordless Drill
- Hammer
- Tape Measure
- Level
- Stool or Short Ladder
- Shovel

### General Information

- **Read Instructions through carefully before beginning assembly.**
- When assembling components, place on a non-abrasive surface (i.e. shipping box) to avoid scratching.
- We recommend an area approx 10'x 8' for unobstructed assembling.
- You should not need to use excessive force when assembling components.

## STEP ONE

### Assemble the Arch System

**1**

Insert arches into arch keystone ensuring they terminate flush to the internal connector. The tabs sticking out of the internal connector should fit outside the arches. Ensure that the arches are orientated properly as per illustration.

**2**

Fasten the arch system to the keystone by installing the screws into the 2 pre-drilled holes provided.

**3**

Invert the arch system and install two screws from the bottom of the keystone into the two pre-drilled flanges on either side of the bottom of the insert. This will connect the bottom of the arches to the insert.

**4**

Seal the bottom hole on the keystone by inserting the bottom plate as provided.

**5**

Install the top cap on the arch keystone. Push down firmly so the cap locks into position.

**6**

Repeat for other arch.

**7**

Insert arch rafters (6) into the holes on the arches until they bottom out inside the arches. There are "locking tabs" located at each end of these rafters that once inserted into the holes will lock into place.

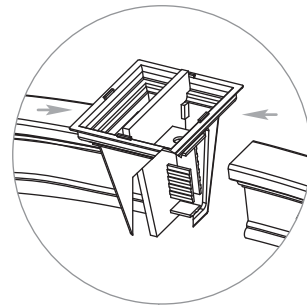

1

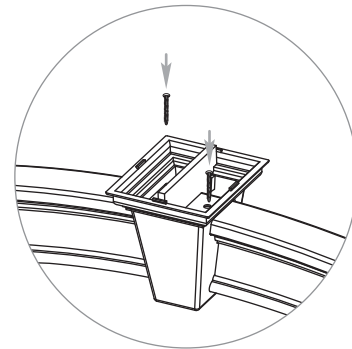
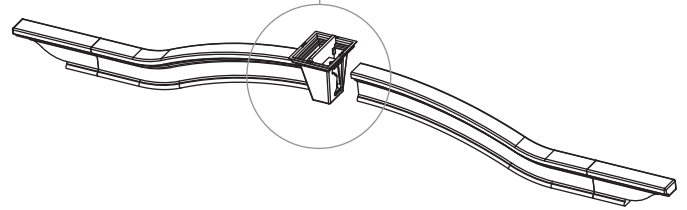

2

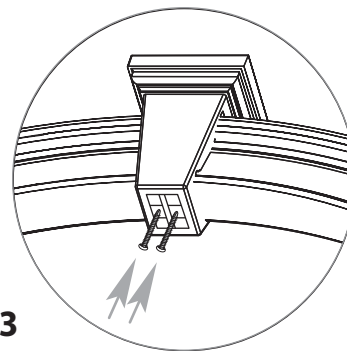

3

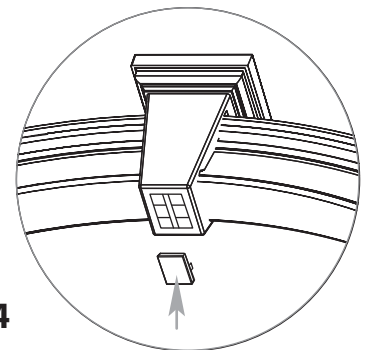

4

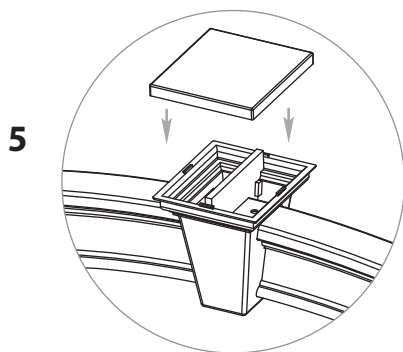

5

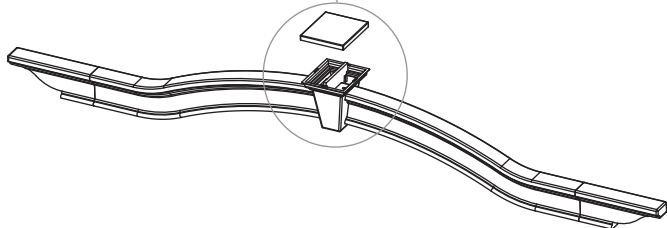

7

## STEP TWO

### Assemble the Side Panels

1

Insert the four short horizontal spindles into the two long and one short vertical spindles.

2

Lay out the horizontal bottom rail and insert three vertical spindles.

3

Slide the horizontal mid-rail over the ends of the spindles.

4

Slide the horizontal bent top rail over the ends to complete one side panel (*ensure that bend is down*).

5

Set out one post and complete the side panel by inserting it into the post. **Start with the bent top rail first.**

6

Lay out the second post with holes facing upwards and insert the completed panel with connected post into.

7

Repeat for other side panel.

**NOTE:** Some of the horizontal rails have locking tabs located at both ends. Once inserted and pushed into the routed holes, they will lock into place.

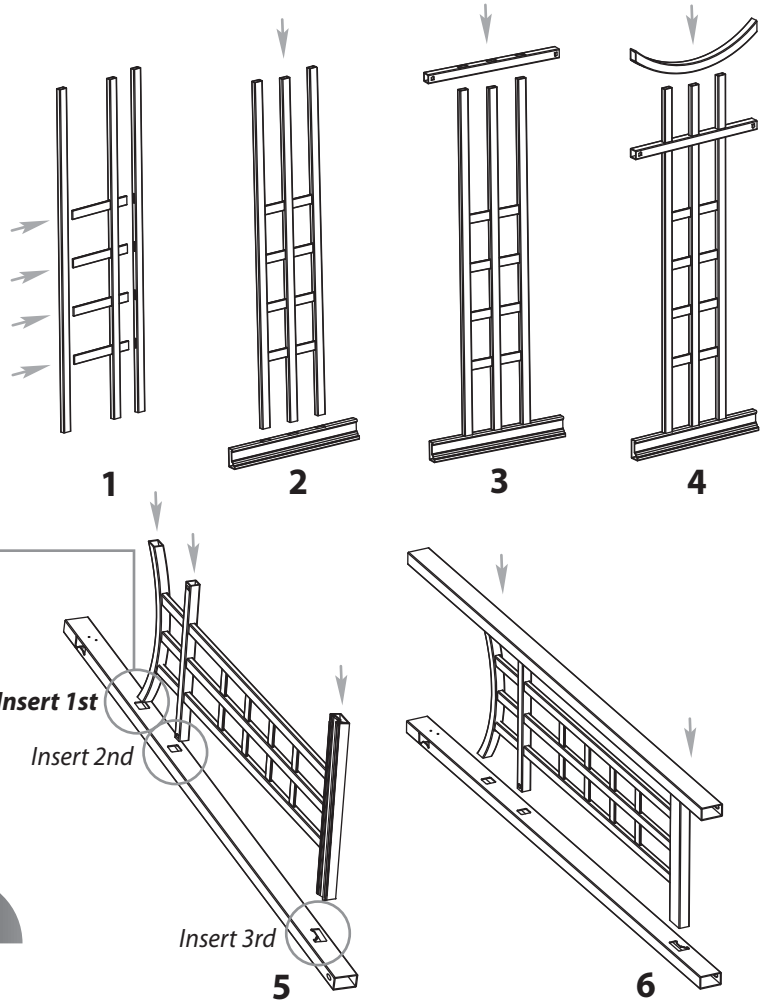

## STEP THREE

### Connect Arch System to Side Panels

1

Set out one side panel **ensuring that holes at the bottom of the post face outwards**. Insert the assembled arch through the holes at the top of the posts. Do the same for the other side panel **ensuring that the holes at the bottom of the post face outwards**. You will need a helper.

2

Adjust the opening width to 42" between the posts.  
(arbor allows for minor variance).

3

Fasten the arch system to the posts by installing the screws provided into the 2-pre drilled holes per post.

4

Place posts caps on top of posts.

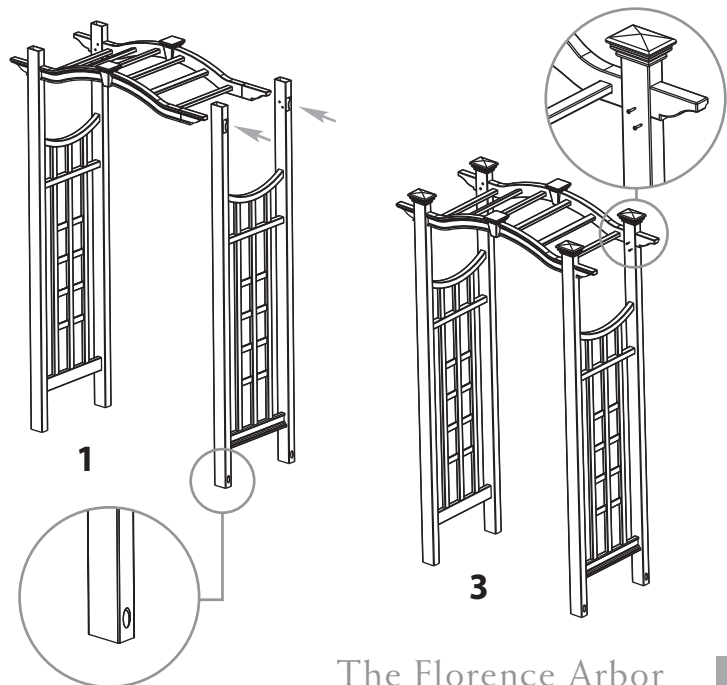

## STEP FOUR

### Arbor Installation

Arbors must be well secured to prevent tipping over from wind load etc. We have provided four ground anchors for securing the arbor either into the ground or a concrete footing. In some cases it may be acceptable to secure the arbor to an existing structure such as a fence post. If you are installing your arbor on concrete or a deck, see your hardware store for the appropriate galvanized bracketing hardware.

#### A - Into Earth Without Concrete Footing

1

Move the arbor to its final location (you will need a helper). When you are satisfied with the location, mark the positions of the posts, then move the arbor aside and lay it carefully on its side. Excavate 4 holes approx 3" deep. Carefully move the arbor back into position and level it both vertically and horizontally.

2

Drive the four post anchors on appropriate angle through the hole at the bottom of the posts.

3

Backfill the holes with the excavated soil to cover the anchors.

#### B - Into Earth With Concrete Footing

1

Complete A #1 above, with the exception of excavating the holes at least 6" wide x 18" deep. Fill holes with wet cement within 3" of your grade (you will need 2 bags of pre-mix concrete - purchase separately). Carefully move the arbor back into position.

2

Support the arbor plumb and level over the holes with bricks, stones or blocks of wood under the bottom rail of the side panel. The post bottoms should insert themselves approx 1/2" into the concrete.

3

Push the 4 anchors into the hole on the bottom of the posts at the appropriate angle (you will need to do this quickly as your cement will begin to cure).

#### Optional

If you plan on attaching a fence or bench to the arbor, or in the event of extreme wind conditions we would not recommend using the ground anchors provided. Consider purchasing 2x4 pressure treated lumber and trimming down to size and cutting it into 36" lengths. Insert into the bottom of all four posts until they hit the bottom horizontal rail on the side panel. Fasten accordingly with screws and install either directly into the ground or into a concrete footing.

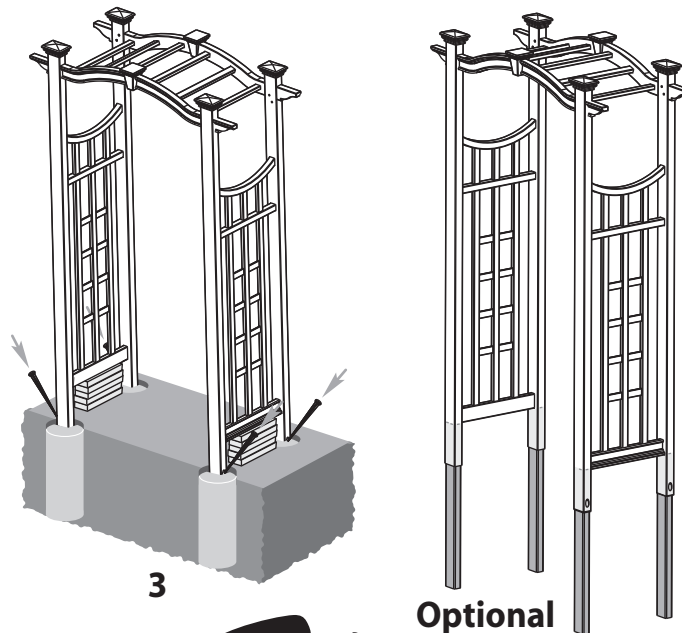
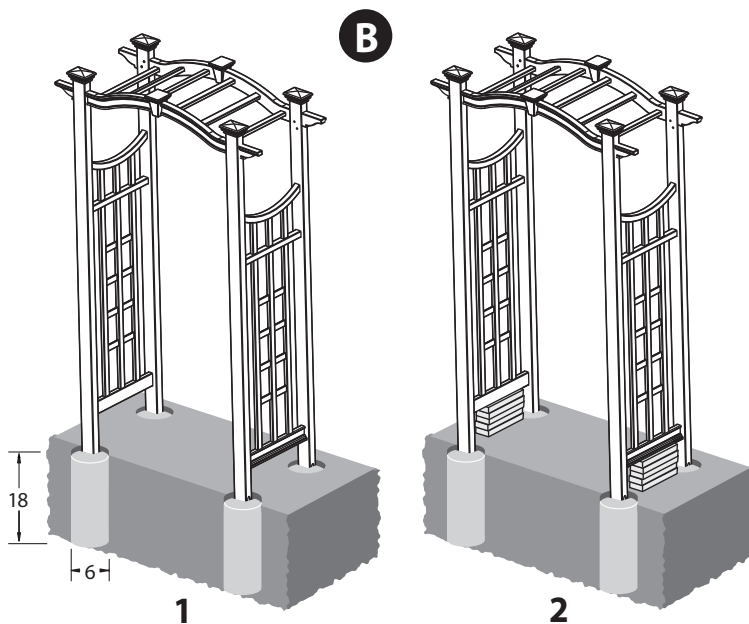
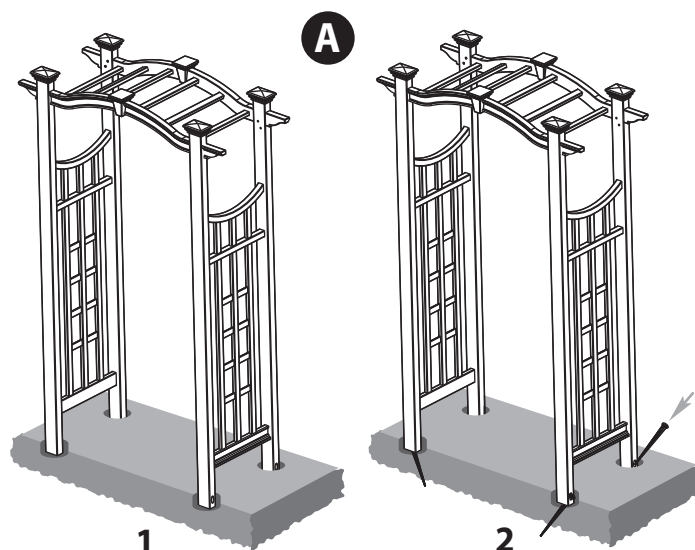

Optional

2" x 4" Wood Insert  
(Purchase Separately)

Eden™

Enduring Garden Architecture